

Model A12-17

Combustible Gas Transmitter

Home Office

Analytical Technology, Inc.
6 Iron Bridge Drive
Collegetown, PA 19426

Ph: 800-959-0299
610-917-0991

Fax: 610-917-0992

Email: sales@analyticaltechnology.com

European Office

ATI (UK) Limited
Unit 1 & 2 Gatehead Business Park
Delph New Rd. Delph
Saddleworth OL3 5DE
Ph: +44 (0) 1457-873-318

Fax: + 44 (0)1457-874-468

Email: sales@atiuk.com

PRODUCT WARRANTY

Analytical Technology, Inc. (Manufacturer) warrants to the Customer that if any part(s) of the Manufacturer's products proves to be defective in materials or workmanship within the earlier of 18 months of the date of shipment or 12 months of the date of start-up, such defective parts will be repaired or replaced free of charge. Inspection and repairs to products thought to be defective within the warranty period will be completed at the Manufacturer's facilities in Collegeville, PA. Products on which warranty repairs are required shall be shipped freight prepaid to the Manufacturer. The product(s) will be returned freight prepaid and allowed if it is determined by the manufacturer that the part(s) failed due to defective materials or workmanship.

This warranty does not cover consumable items, batteries, or wear items subject to periodic replacement including lamps and fuses.

Gas sensors, except oxygen sensors, are covered by this warranty, but are subject to inspection for evidence of extended exposure to excessive gas concentrations. Should inspection indicate that sensors have been expended rather than failed prematurely, the warranty shall not apply.

The Manufacturer assumes no liability for consequential damages of any kind, and the buyer by acceptance of this equipment will assume all liability for the consequences of its use or misuse by the Customer, his employees, or others. A defect within the meaning of this warranty is any part of any piece of a Manufacturer's product which shall, when such part is capable of being renewed, repaired, or replaced, operate to condemn such piece of equipment.

This warranty is in lieu of all other warranties (including without limiting the generality of the foregoing warranties of merchantability and fitness for a particular purpose), guarantees, obligations or liabilities expressed or implied by the Manufacturer or its representatives and by statute or rule of law.

This warranty is void if the Manufacturer's product(s) has been subject to misuse or abuse, or has not been operated or stored in accordance with instructions or if the serial number has been removed.

Analytical Technology, Inc. makes no other warranty expressed or implied except as stated above.

TABLE OF CONTENTS

INTRODUCTION	2	CALIBRATION	22
<i>Figure 1: Transmitter Components</i>	3	ZERO ADJUSTMENT	22
<i>Figure 2: Typical System Diagram</i>	4	<i>Figure 15 - Calibration Adapter Assembly</i>	22
SPECIFICATIONS	5	SPAN ADJUSTMENT	23
INSTALLATION.....	6	MA OUTPUT ADJUSTMENT	24
<i>Figure 3: Gas Transmitter Dimensions, No Auto-Test</i>	6	AUTO-TEST ENABLE/DISABLE SELECTION (UNITS	
<i>Figure 4: Gas Transmitter Dimensions, with Auto-Test</i>	7	WITH AUTO-TEST).....	24
.....	7	CALIBRATION FOR OTHER COMBUSTIBLE GASES	
SENSOR LOCATION.....	8	25
INTERFERENCES	8	SENSOR RESPONSE TEST.....	25
ELECTRICAL CONNECTIONS – TRANSMITTER.....	9	ERROR MESSAGES	26
<i>Figure 5: Transmitter connections, no Auto-Test.....</i>	9	SENSOR REPLACEMENT	27
<i>Figure 6: Transmitter connections, with Auto-Test... 10</i>	10	SPARE PARTS LIST	28
DUAL CONDULET SYSTEM	11		
<i>Figure 7: Dual Condulet Connections, Sensor w/o</i>			
<i>Auto-Test</i>	11		
<i>Figure 8: Dual Condulet Connections, Sensor with</i>			
<i>Auto-Test</i>	11		
<i>Figure 9: Dual Condulet Typical Installation.....</i>	12		
A12-17 TO B14 CUSTOMER WIRING DIAGRAM... 13	13		
<i>Figure 10 –B14 Receiver Connections.....</i>	13		
A12-17 TO GENERIC INSTRUMENT WIRING			
DIAGRAM	14		
<i>Figure 11 – Generic Instrument customer wiring</i>	14		
OPERATION.....	15		
START-UP	15		
START-UP DELAY	16		
FRONT PANEL MAGNETIC CONTROLS	16		
<i>Figure 12 - Model A12-17 Front Panel</i>	16		
LIQUID CRYSTAL DISPLAY	17		
<i>Figure 13 - Liquid Crystal Display</i>	17		
MENU SEQUENCE.....	18		
<i>Figure 14 - Transmitter Program Chart</i>	18		
<i>Figure 14 cont'd - Transmitter Program Chart</i>	19		
TRANSMITTER MODE SELECTION	20		
INFORMATION MODE.....	20		
TEST MODE.....	20		
MANUAL AUTO-TEST ACTIVATION.....	20		
ANALOG OUTPUT SIMULATION	21		

INTRODUCTION

The model A12-17 is an advanced combustible gas transmitter providing reliable measurement of combustible gas levels in industrial plant environments. A12-17 transmitters combine catalytic bead type gas sensors and an electronic amplifier that transmits gas concentration using a standard 4-20 mA signal. Transmitter electronics provide a local LCD display of gas concentration and contain magnetic controls to allow testing and calibration without opening the enclosure. Typical applications are ambient air monitoring near process tanks or piping, or in enclosed spaces where combustible gases may leak or accumulate.

The A12-17 transmitters are composed of two main parts, the gas sensing element and the electronic transmitter. The sensor is an explosion-proof assembly made of type 316 stainless steel with a flame arrestor bonded at the sensing end. The electronic transmitter is a plug-in module housed in an explosion-proof cast aluminum housing with an epoxy powder coating suitable for areas designated Class I, Groups B, C, & D; Class II, Groups E & F, and Class III. Sensors are normally screwed directly into the transmitter enclosure and connected with a short cable. However, sensors can be mounted remote from the transmitter up to 50 feet, provided that sensor cables are properly protected in explosion-proof conduit.

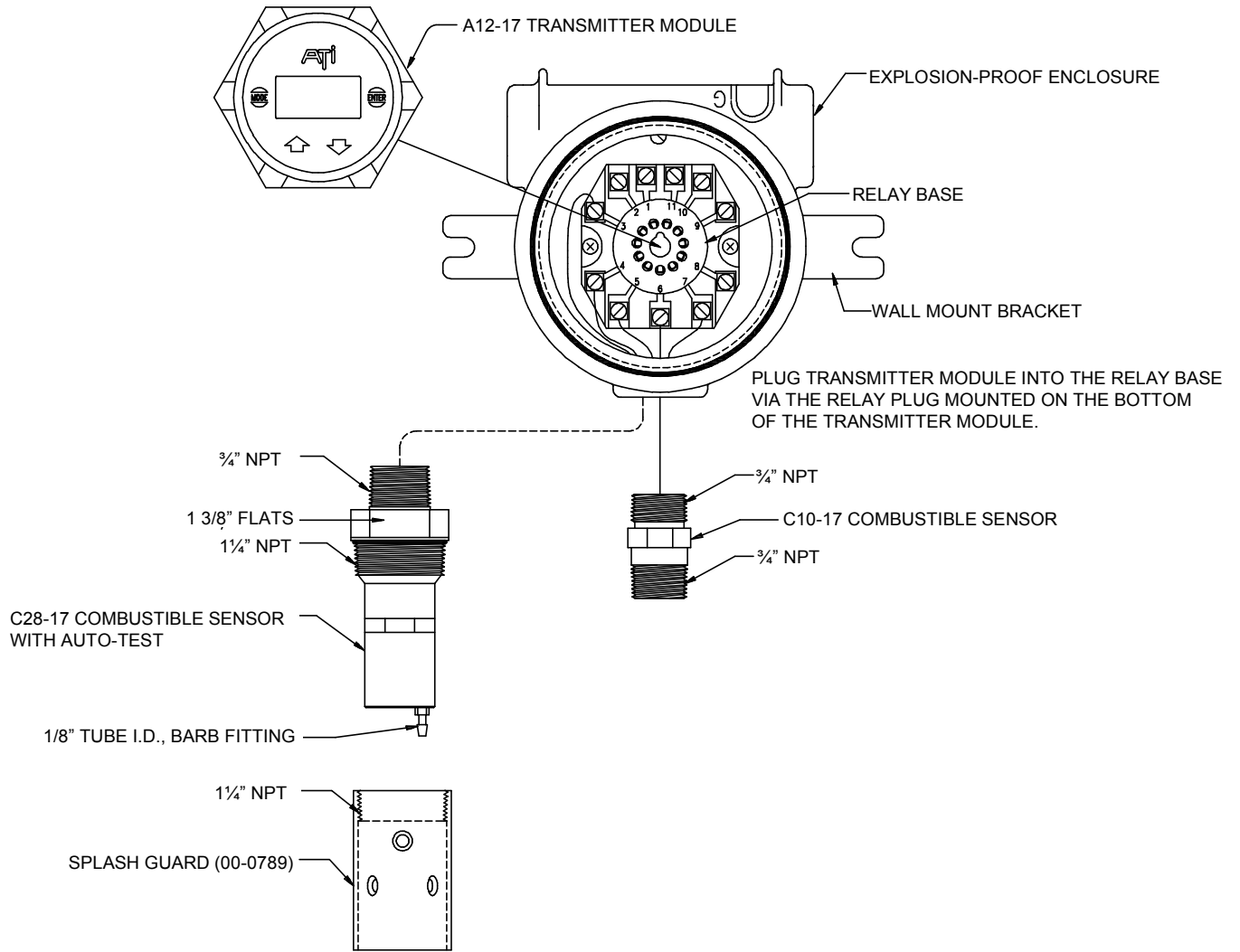

Figure 1: Transmitter Components

Model A12-17 transmitters are available with a unique sensor verification system called Auto-Test. This option consists of a miniature gas generator incorporated into the explosion-proof sensor assembly which automatically generates a combustible gas every 24 hours. The gas generator function is controlled by the microcontroller in the transmitter electronics. When activated, the generator will provide a true gas test of the combustible gas sensing element, and will automatically alert operators to sensor problems that might develop due to sensor poisoning or coating. Figure 1 shows both a standard sensor and a sensor equipped with the Auto-Test generator.

The Auto-Test feature provides daily verification of sensor response. While it is not intended to replace calibration, the automatic sensor test greatly reduces the amount of manual testing required to assure that the gas detection system is functioning properly. Should a sensor fail to respond to the gas test, the 4-20 mA signal from the transmitter is locked at 3 mA, providing a trouble signal to any receiving equipment.

A typical installation for the A12-17 is shown in Figure 2 below. It is shown connected to ATI's series B14 single channel receiver, but the transmitter may be used directly with PLC, DCS, or computer monitoring systems without the use of a special receiver.

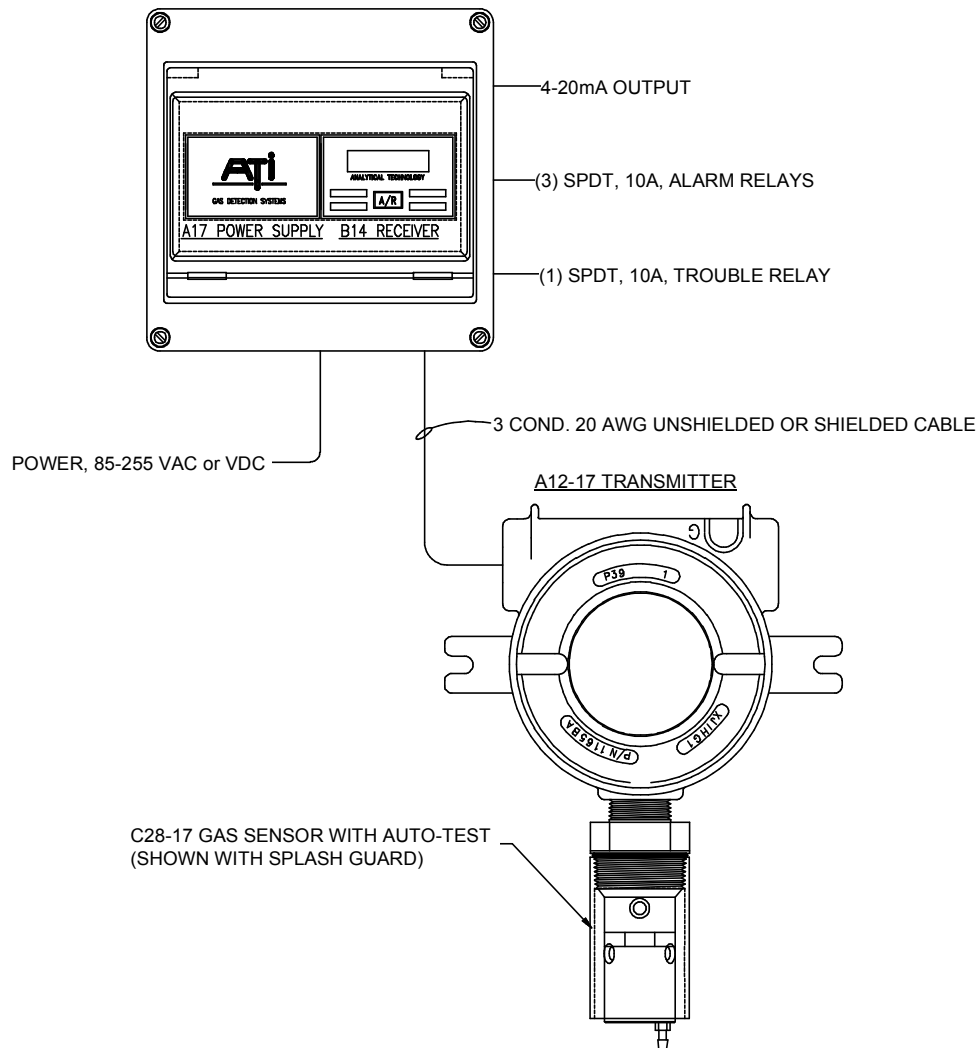

Figure 2: Typical System Diagram

SPECIFICATIONS

Range:	0-100% LEL (Lower Explosive Limit)
Display:	3 Digit LCD
Response Time (T90):	10 Seconds
Sensitivity:	1% LEL
Zero Drift:	< 2%/Month
Power:	12-28 VDC, 12 VDC at 150mA nominal, 200mA max. 24 VDC at 75mA nominal, 100mA max.
Output:	4-20 mA DC, 375 ohms maximum load at 12 VDC 850 ohms maximum load at 24 VDC 1000 ohms maximum load at 28 VDC
Controls:	Four magnetic control switches operable through glass window
Temperature Limits:	-40° to + 70° C.
Sensor Type:	Catalytic bead type, poison resistant
Sensor Option:	Auto-Test gas generator
Sensor Materials:	316 Stainless Steel
Transmitter Enclosure:	Cast Aluminum with Epoxy Coating, Glass window
Area Classification:	NEC Class I, Groups B, C, & D, Class II, Groups E, F & G, Class III
Connections:	3 wire, 20 AWG, 500 feet max. (150 m.)
Sensor Cable Length:	Maximum 50 feet for separation between sensor and transmitter
Weight:	4 lbs. (1.4 Kg.)

INSTALLATION

Combustible gas sensor/transmitters are explosion-proof assemblies that are normally mounted directly to suitable explosion-proof conduit. To maintain the explosion-proof integrity of the transmitter, a suitable cable entry seal must be used in accordance with the applicable electrical code. Sensor/transmitters should be mounted with the sensor facing down as shown in Figure 3 and 4. A12-17 transmitters are also supplied with a mounting bracket that can be used to secure the unit to a wall or plate.

NOTE: Gas sensors without auto-test are shipped with a protective plastic cap over the end. This cap should be left in place to avoid damage to the sensor during installation. If the detection system is to be activated within a few days of installation, the cap should be removed when installation is complete. Otherwise, leave the cap in place until the system is to be placed in service. **Be sure to leave the protective cap on the sensor if painting is to be done in the area of the sensor.**

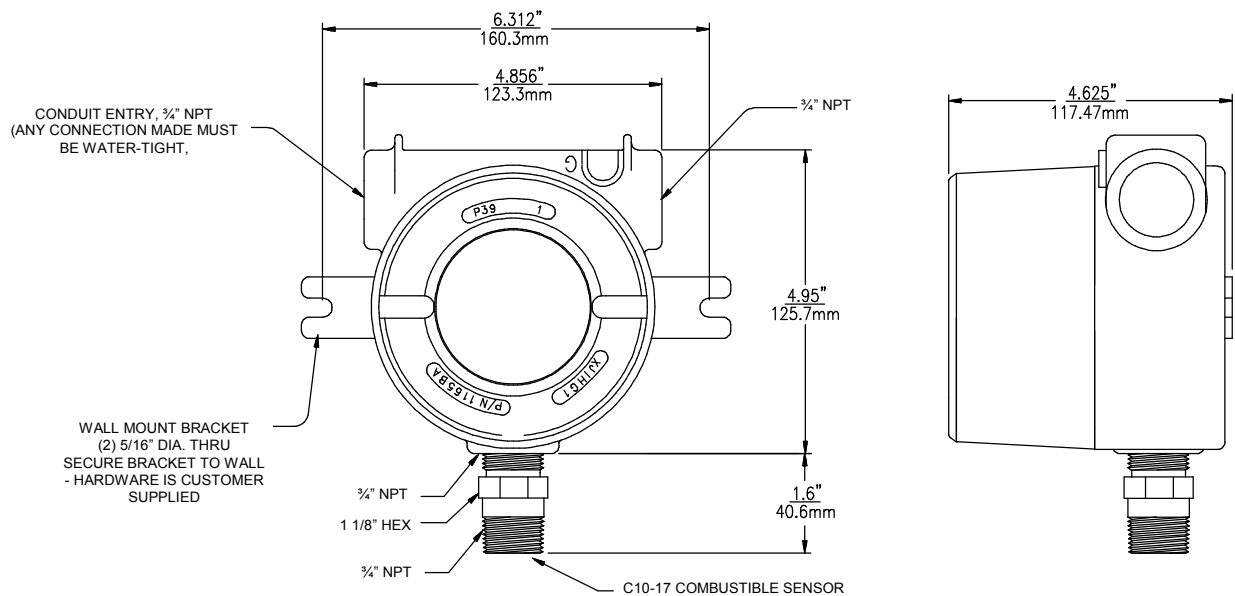

Figure 3: Gas Transmitter Dimensions, No Auto-Test

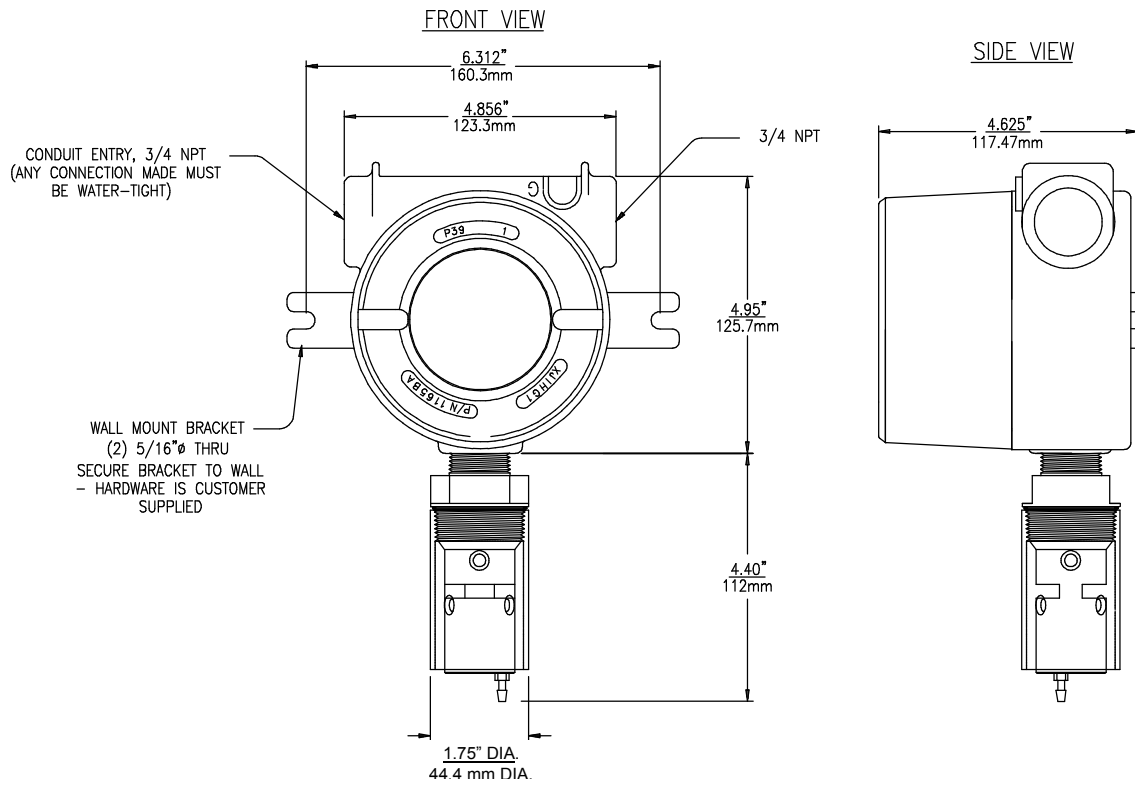

Figure 4: Gas Transmitter Dimensions, with Auto-Test

SENSOR LOCATION

Combustible gas sensors are used to detect a variety of gases or vapors. The proper sensor location will depend on the type of gas is expected. For gases that are lighter than air, such as methane, sensors should be located near the ceiling. For gases that are heavier than air, such as butane, sensors should be mounted near the floor. If the gas or vapor has a density near that of air, locate the sensor about 5 feet off the floor in enclosed areas. Gas sensors mounted outdoors should be located near anticipated leak sources (valves, flanges, compressors, etc.) and the location will depend on normal wind patterns and anticipated employee activity areas.

The following are a few common combustible gases, along with their relative density (air = 1.00). Densities less than one indicate gases that are lighter than air while those with densities greater than one are heavier than air. Combustible vapors from most solvents, such as Benzene, n-Hexane, Methanol, Ethanol, and MEK, are heavier than air and will tend to accumulate near the floor in enclosed spaces with little air movement.

Methane	0.55
Butane	2.11
Propane	1.55
Hydrogen	0.07
Ammonia	0.60

INTERFERENCES

Combustible gas sensors contain two heated elements. One of these elements is active, and will allow combustible gases or vapors to burn on its catalytic surface. The other is passive, and does not react to gases. These two elements form two legs of a Wheatstone bridge measuring circuit. When combustible gas contacts the sensor, the active element burns this gas and the temperature of this element increases, changing its resistance. The transmitter measures the imbalance in the bridge circuit and transmits the data to the receiver for display and alarming purposes.

Combustible sensors are adversely affected by a few compounds that may be present in a given application. Probably the worst of these are silicone vapors from silicon based lubricants or sealants. High silicon vapor concentrations can cause complete loss of sensitivity in as little as a few hours. These sensors should not be used where silicon vapors are normally present, and sensors should be protected from these vapors if such compounds are in use temporarily.

Lead compounds and high levels of hydrogen sulfide can also cause degradation of combustible sensors. While lead vapors are not commonly encountered, they can also cause complete sensor failure if encountered. Hydrogen sulfide will cause reduced sensitivity over the first few weeks of exposure, but then will level out. The effect of hydrogen sulfide can normally be compensated for by re-calibration after the first few weeks of use.

ELECTRICAL CONNECTIONS – TRANSMITTER

External connections to the A12-17 transmitter can be made using 3 conductor cable. Three conductor cable uses one conductor (GND) as the power supply and output signal common. Figures 5 and 6 show power, output, and sensor connections for transmitters with and without Auto-test.

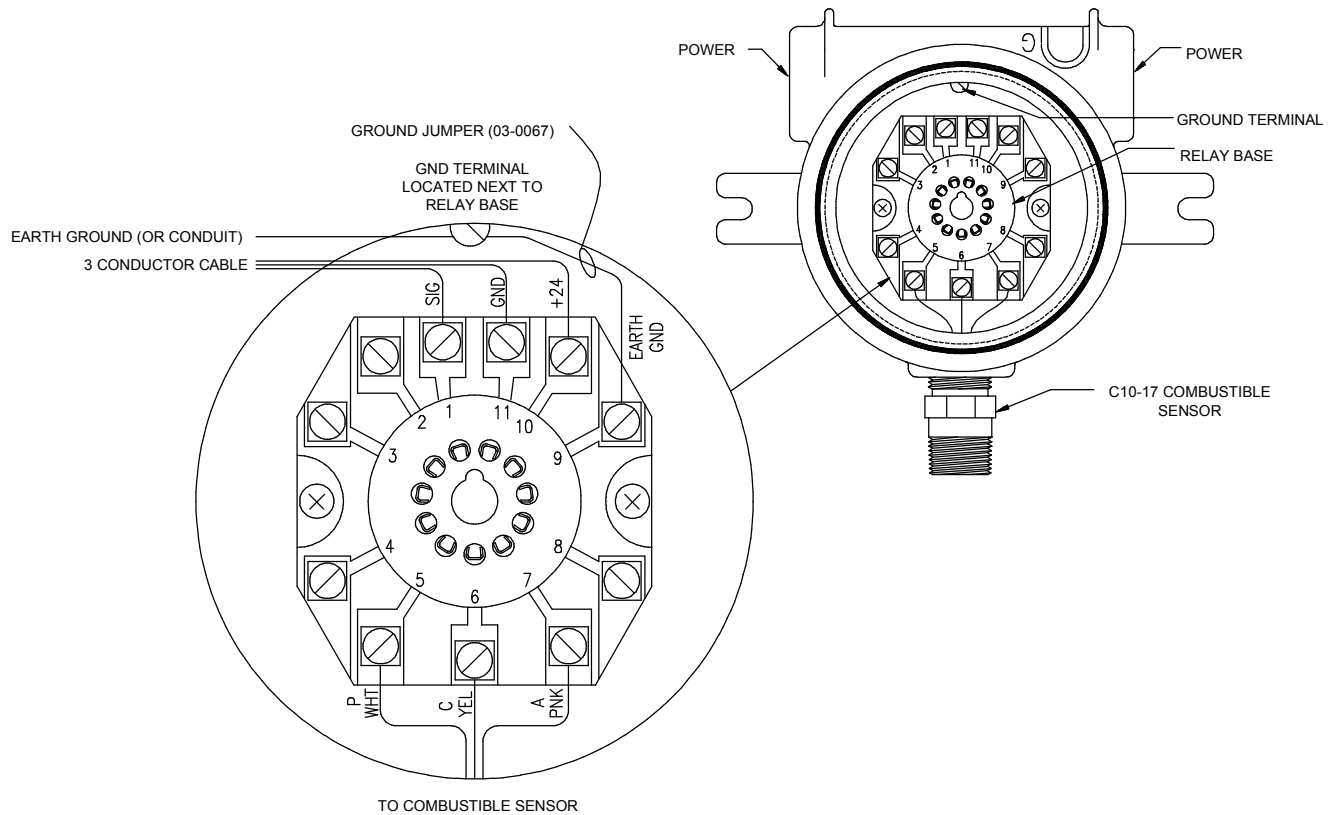

Figure 5: Transmitter connections, no Auto-Test

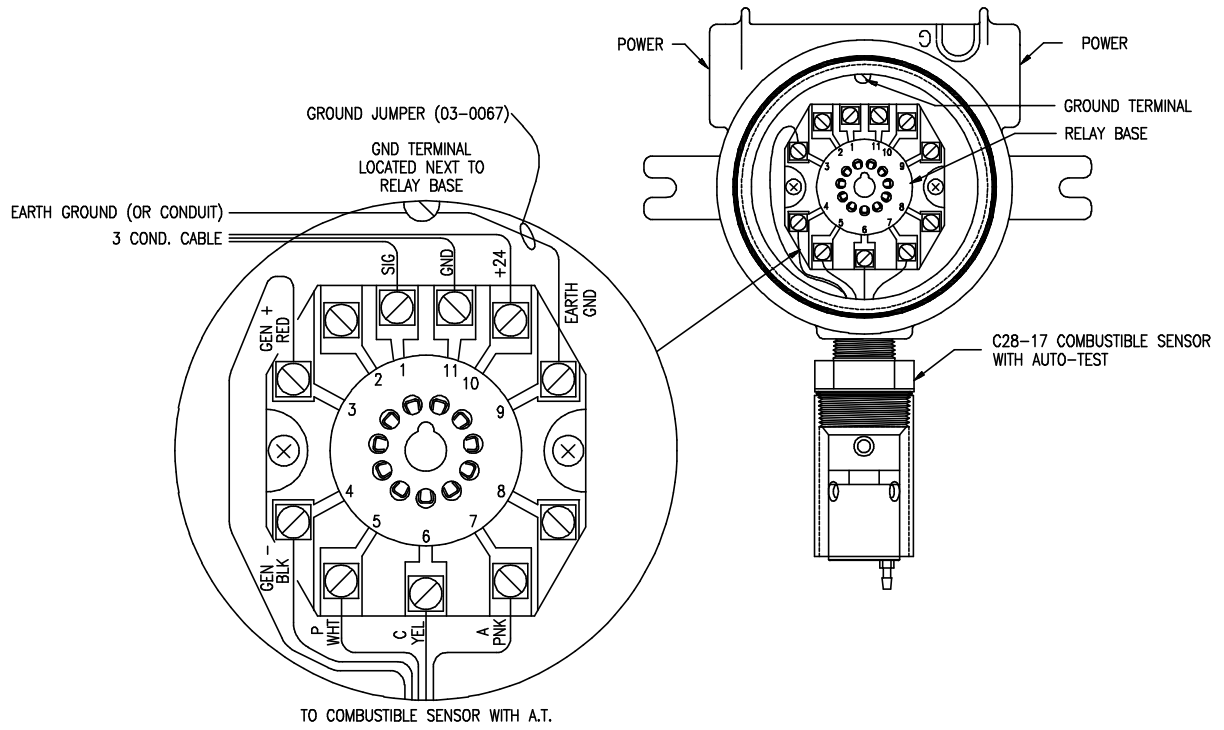

Figure 6: Transmitter connections, with Auto-Test

DUAL CONDULET SYSTEM

For some indoor applications, it is more convenient to mount the sensor toward the ceiling of the room while keeping the transmitter electronics down at a convenient elevation for making calibration adjustments. ATI's dual Condulet system is designed for this purpose, and the interconnecting wiring is shown below. A special remote calibration adapter can be used with this system to allow gas to be fed from a point near the transmitter as shown in Figure 9

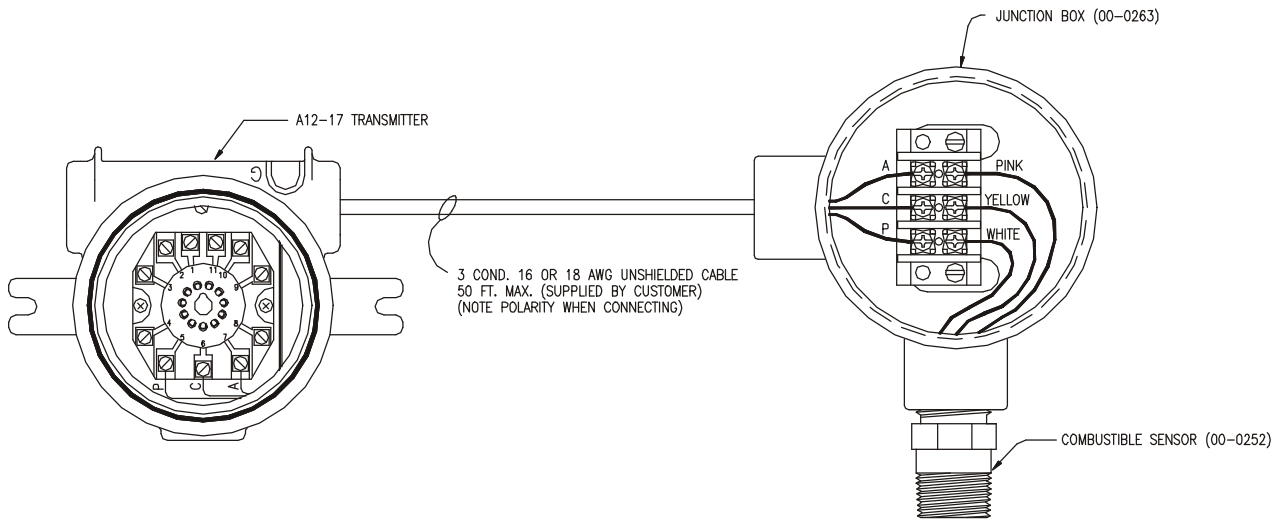

Figure 7: Dual Condulet Connections, Sensor w/o Auto-Test

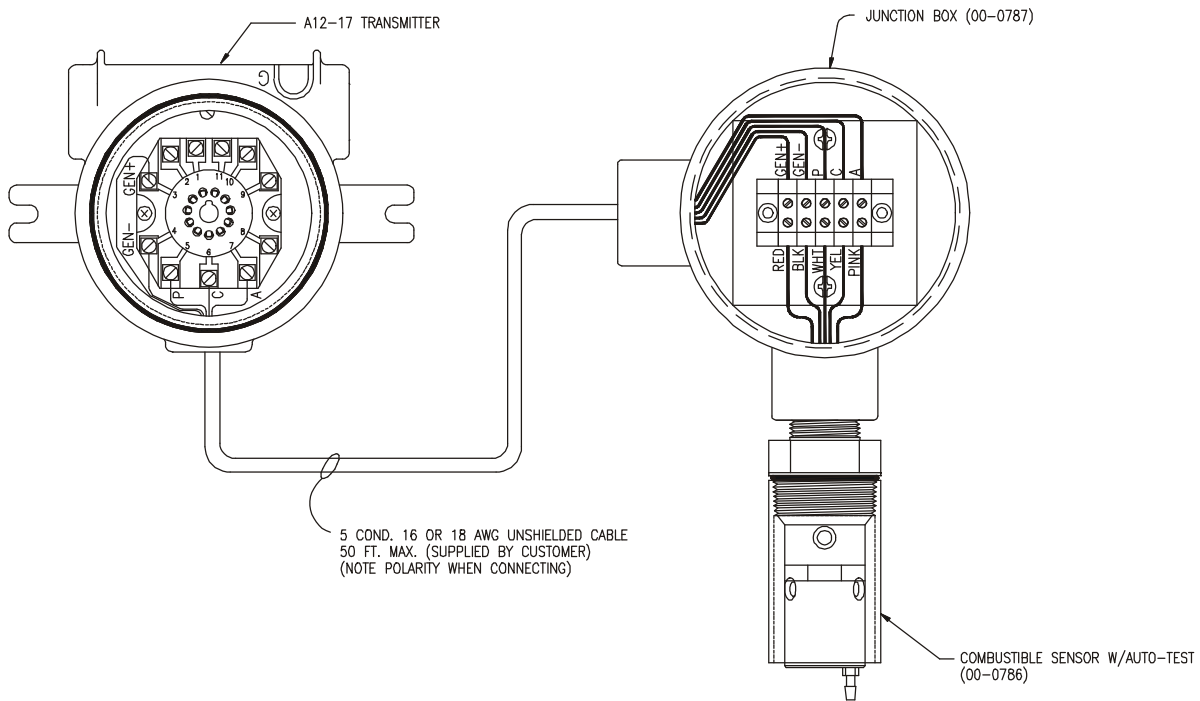

Figure 8: Dual Condulet Connections, Sensor with Auto-Test

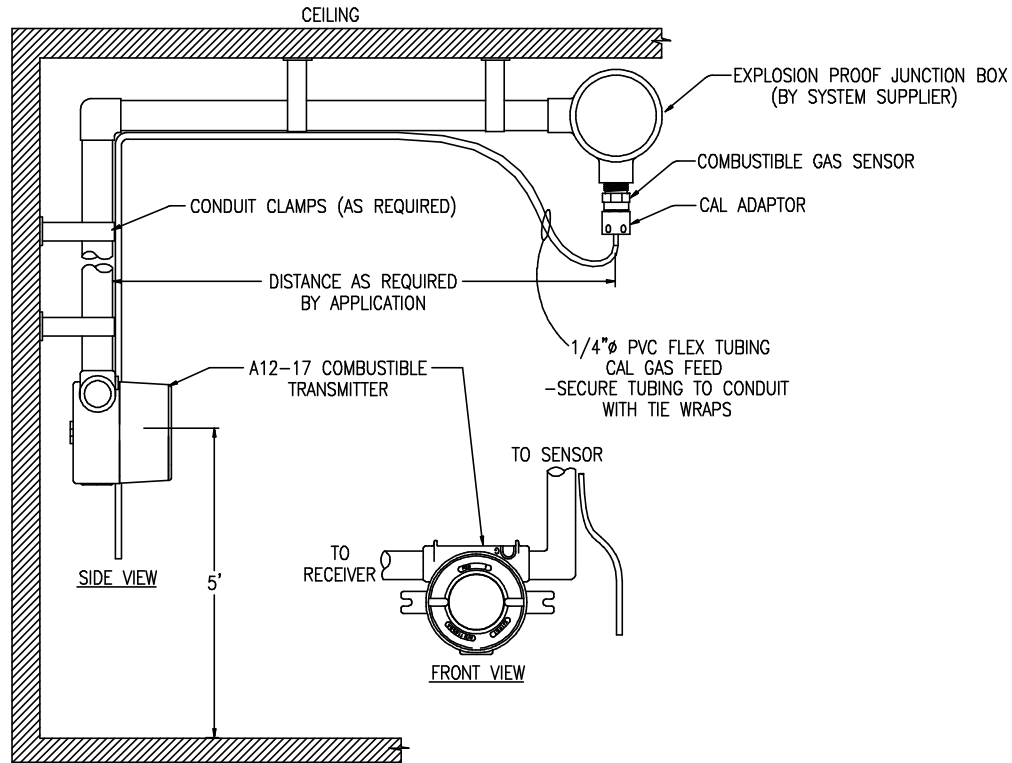

Figure 9: Dual Condulet Typical Installation

A12-17 TO B14 CUSTOMER WIRING DIAGRAM

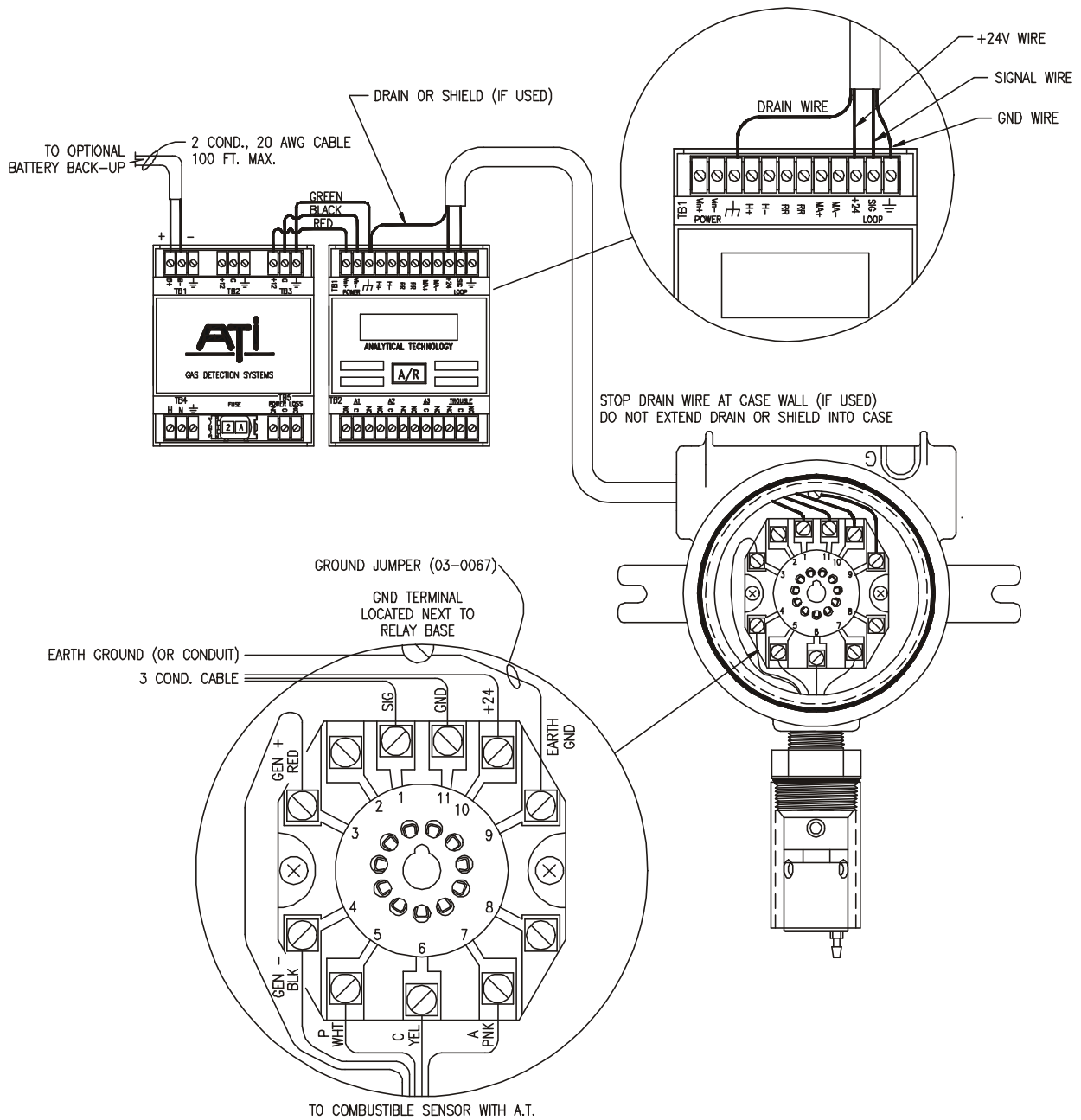

Figure 10 –B14 Receiver Connections

A12-17 TO GENERIC INSTRUMENT WIRING DIAGRAM

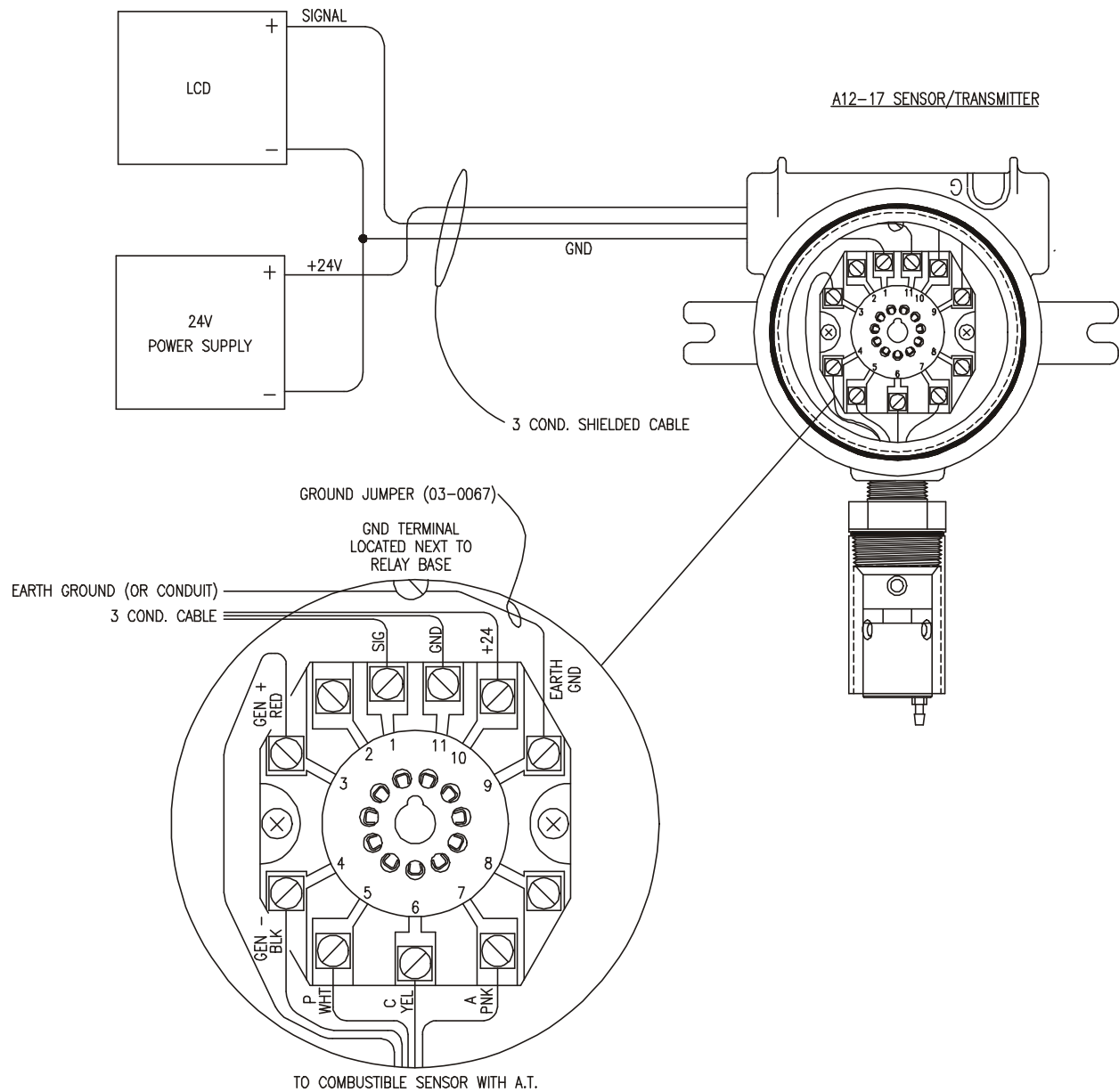

Figure 11 – Generic Instrument customer wiring

OPERATION

After mechanical and electrical installation is complete, the transmitter is ready for operation. Prior to start-up, recheck the wiring connections to be sure power is connected to the proper terminals.

START-UP

When power is first applied, the transmitter will go through a start-up sequence. The LCD display will indicate the following information.

tr X.X	Indicates transmitter program version number
17	Two digit gas code number for combustible gas
100 %LEL	Full scale range of the transmitter
InSt/nonE	InSt - Indicates the sensor contains an Auto-Test generator. nonE - Indicates the sensor does not contain an Auto-Test generator
Enab/disA	*Enab - Indicates the automatic, 24Hr Auto-Test function is enabled. disA - Indicates the automatic, 24Hr Auto-Test function is disabled.
XX.XH	*Number of hours until the next automatic, 24Hr Auto-Test
XXXX	*Number of <u>successful</u> sensor Auto-Tests.
XXXX	*Number of <u>unsuccessful</u> sensor Auto-Tests.
All Segments	Display test which powers up all display segments and flags

- Only displayed when the Auto-test generator is installed.

START-UP DELAY

When the start-up sequence is complete, the display will begin to indicate gas concentration and will display the mA lock flag, indicating that a start-up delay is in progress and that the mA output is locked at 4.0 mA. The delay period is 5 minutes, which provides time for the sensor to stabilize near zero before the output is released. After 5 minutes, the lock flag will disappear and the output will begin to track the gas concentration. The start-up delay can be canceled by activating the UP or DOWN arrow with the magnetic screwdriver supplied with the unit.

FRONT PANEL MAGNETIC CONTROLS

The front of the transmitter module contains 4 magnetically activated controls. As shown in Figure 12, these controls are MODE, ENTER, UP, and DOWN. A screwdriver with a suitable magnet is supplied with each transmitter. This magnet allows for operation of the transmitter controls without removing the cover of the outer enclosure. Magnetic controls are used for displaying information about the operation of the transmitter, and performing zero and calibration functions. These controls also allow manual activation of the Auto-Test function, and simulating manual adjustment of the 4-20 mA output to 4 different values for full system verification.

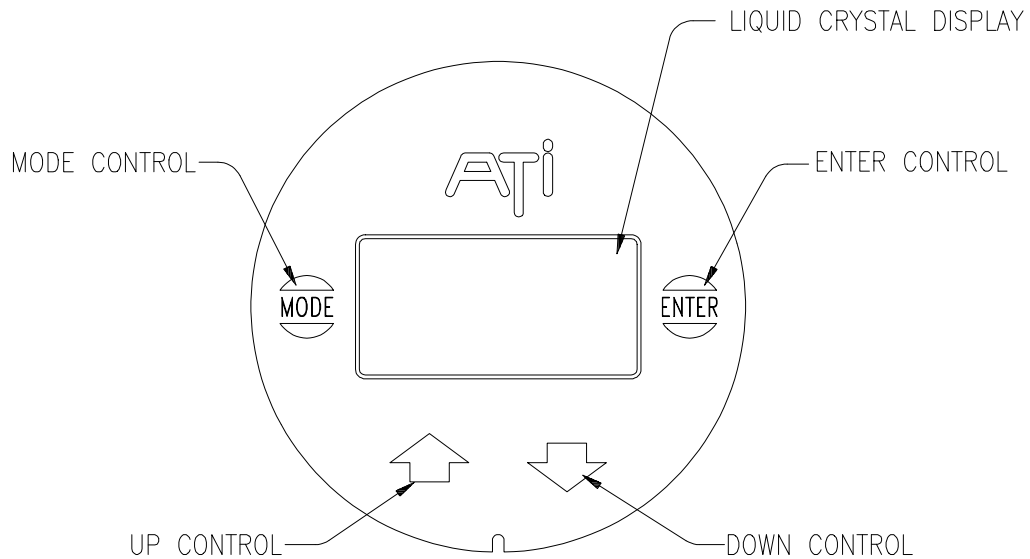

Figure 12 - Model A12-17 Front Panel

LIQUID CRYSTAL DISPLAY

The display in the A12 transmitter provides the operator with a real time concentration display and a variety of prompts for selecting transmitter operating modes. Figure 13 shows the display, including all of the special indicators contained in it. Below the Figure is a description of each indicator.

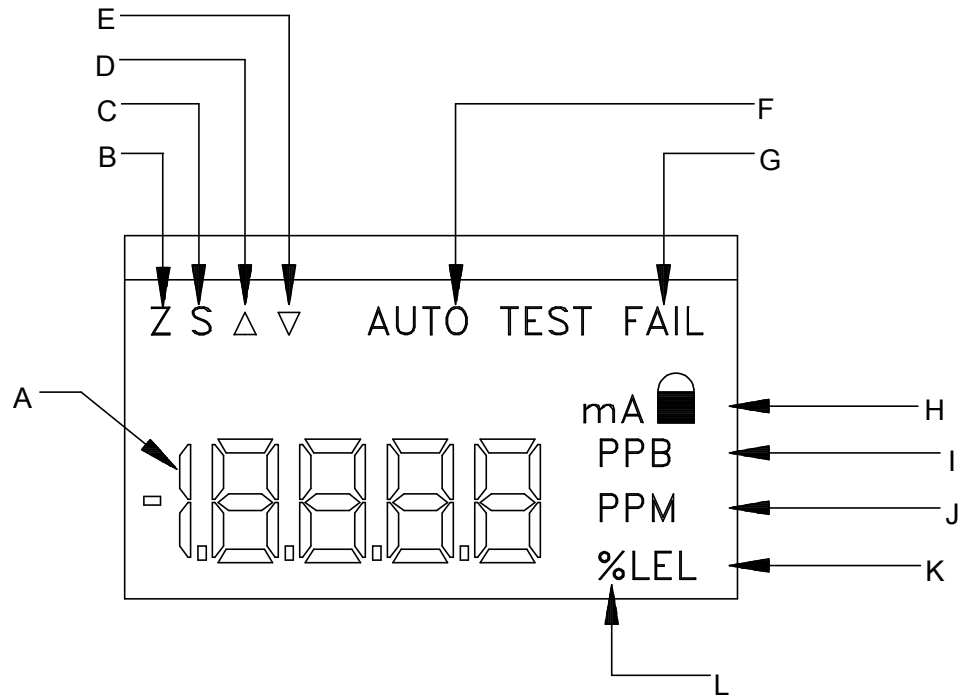

Figure 13 - Liquid Crystal Display

- A - Digital Concentration Display
- B - Zero Indicator, activated while zeroing a sensor module or adjusting the 4 mA output value.
- C - Span Indicator, activated while spanning a sensor module or adjusting the 20 mA output value.
- D - Down Key Indicator, activated when the magnetic control marked “↓” is activated.
- E - Up Key Indicator, activated when the magnetic control marked “↑” is activated.
- F - Auto-Test Indicator, activated when the transmitter is running the Auto-Test routine.
- G - Fail Indicator, activated when an Auto-Test failure is detected.
- H - mA Indicator, activated during output simulation mode or when the output is locked.
- I - PPB Indicator (not used for combustible gas transmitters).
- J - PPM Indicator (not used for combustible gas transmitters).
- K - LEL Indicator, normally activated for combustible gas units.
- L - % Indicator, normally activated for combustible gas units.

MENU SEQUENCE

Operation of the transmitter is accomplished from the front panel using magnetic controls, with the LCD providing visual indication of menu selections. Through menu selections, the user can review information about the transmitter, calibrate the transmitter, manually activate the Auto-Test function (if installed), simulate 4 different mA output values, and reset the transmitter to normal operation in the event of an Auto-Test failure. Figure 14 provides a block diagram of the program in the A12-17 transmitter.

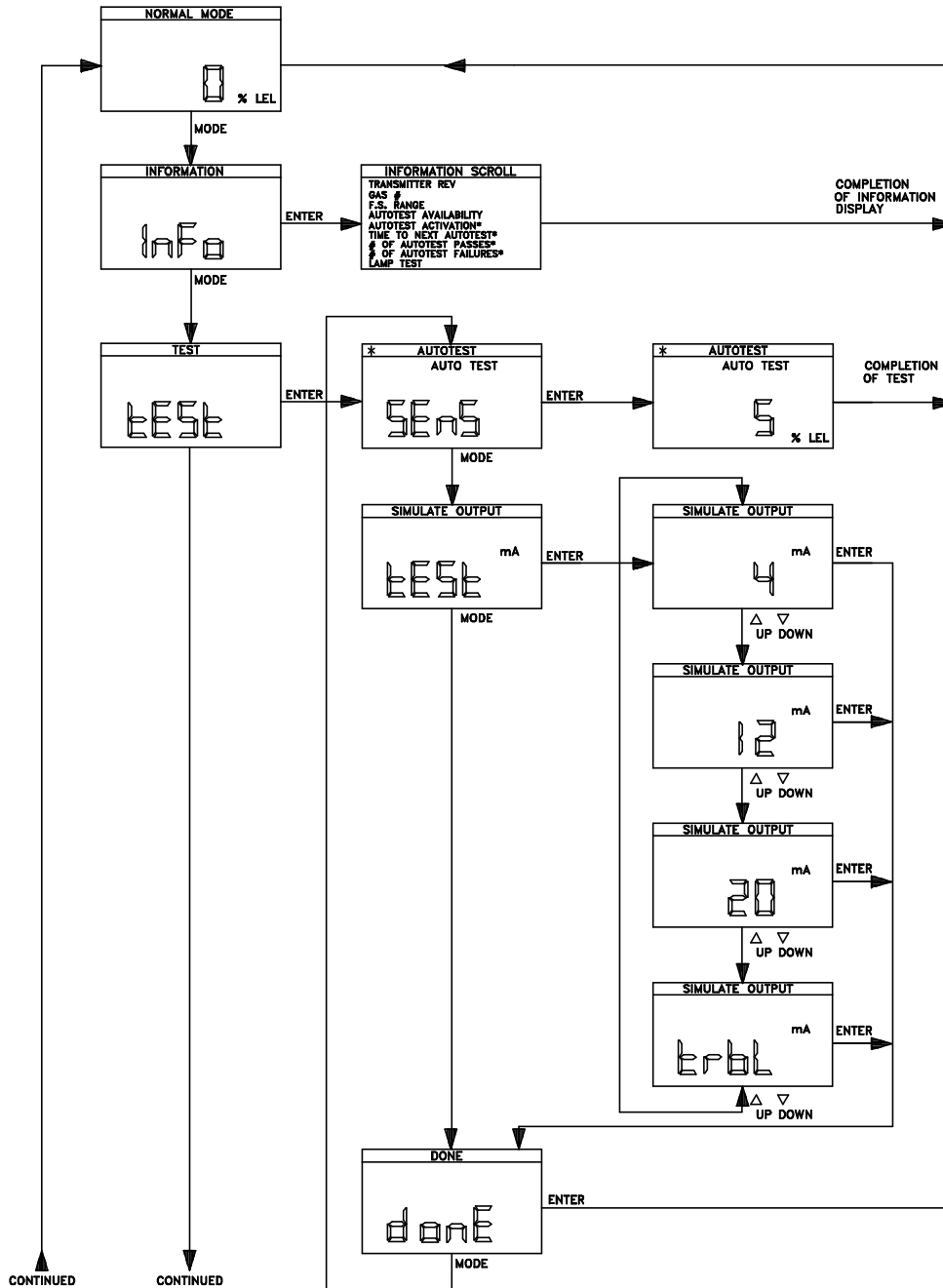

Figure 14 - Transmitter Program Chart

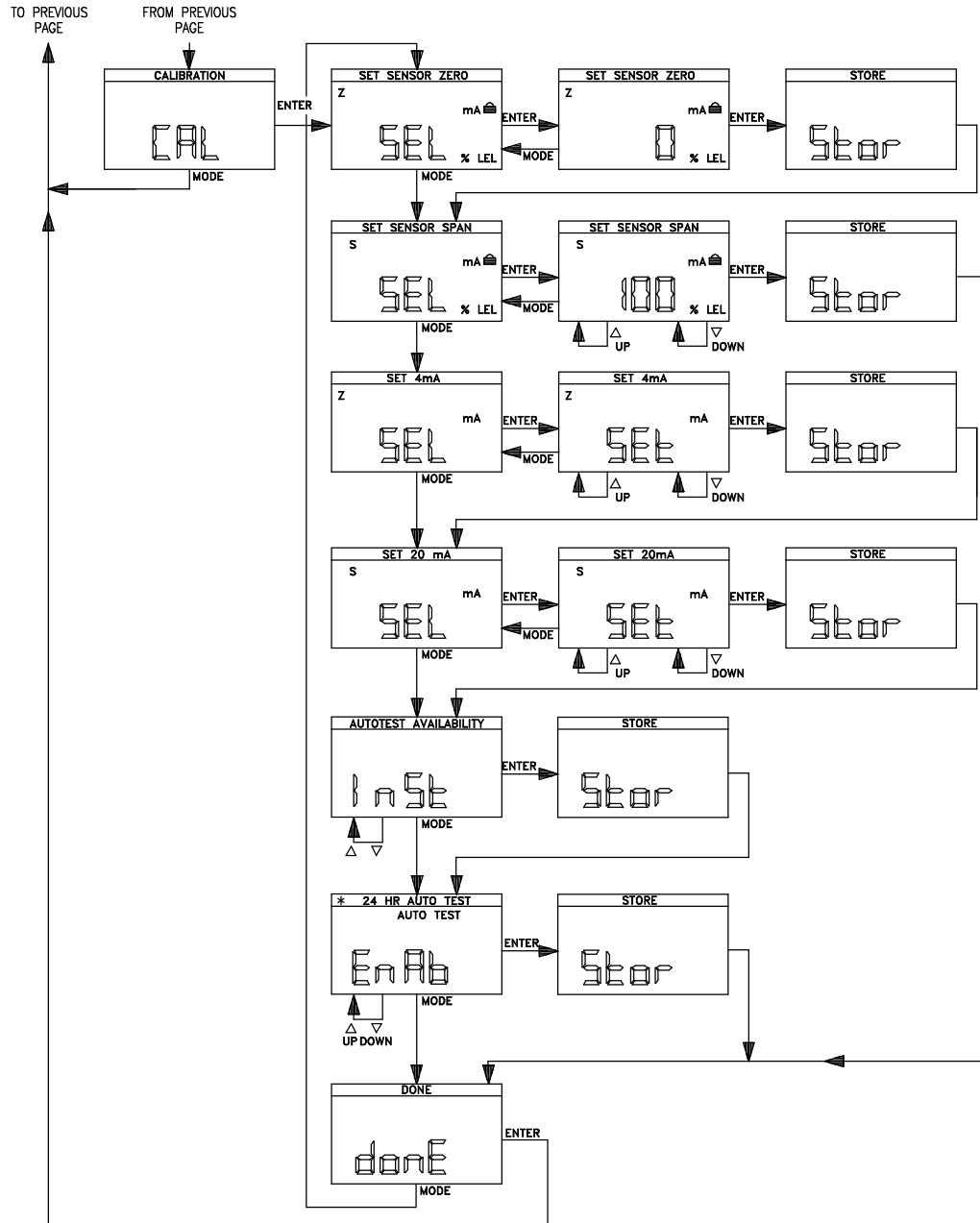

Figure 14 cont'd - Transmitter Program Chart

TRANSMITTER MODE SELECTION

The transmitter provides 4 main mode selections. After the display scrolls through the power-up sequence and completes the start-up delay, it enters the NORMAL mode of operation, displaying gas concentration. By holding a magnet over the MODE control, the display will indicate "InFo". Repeating this process will change the display to "tEst" and then "CAL". The meaning of these modes is as follows:

- InFo Designates INFORMATION mode. In this mode, you may review the information initially displayed during the power-on sequence.

- tEst Designates TEST mode. In this mode, the Auto-Test generator may be manually activated, and the 4-20 mA output may be tested at 4 set values.

- CAL Designates CALIBRATION mode. In this mode, the zero and span of the sensing module may be adjusted, the 4 and 20 mA output current can be adjusted, and daily Auto-Testing can be enabled or disabled.

INFORMATION MODE

To review the transmitter information, activate the MODE control until the display shows "InFo" and then activate the ENTER control. The display will scroll through the same information shown during power-up. See page 15 for details on the information displays.

TEST MODE

There are two selections available under the TEST menu. The first selection allows manual activation of the Auto-Test by the operator. The Auto-Test option is only available when the Auto-Test generator is installed. The second selection allows the transmitter output to be set to 4, 12, and 20 mA in order to check the devices tied to the output. In addition, a failure condition can be simulated, causing the output to go to about 3 mA.

MANUAL AUTO-TEST ACTIVATION

From the NORMAL display, activate the MODE control twice and the display will read "tEst". Activate the ENTER control. The display will change to "SEnS" and the AUTO TEST flag will be displayed near the top of the display. If you activate the ENTER control at this point, the Auto-TEST sequence will begin and the AUTO TEST flag will begin to flash. Activating the MODE control will allow you to escape from this routine without activating the test sequence.

When the test sequence is activated, the 4-20 mA output will be locked at the value being transmitted before the sequence began, normally close to 4.0 mA. If you observe the LCD, you will see the gas concentration begin to increase as gas is evolved from the generator. When the display reaches 5% above the start value, a PASS message will flash on the display, indicating that the sensor passed the test. At this point the AUTO TEST flag will stop flashing and go to steady on. This indicates that the Auto-Test was successful but that the 4-20 mA output is still locked. The output will stay locked for the next 2 minutes to allow the sensor to recover to zero. In addition, it will remain partially locked for an additional 8 minutes to insure complete sensor recovery before again activating the output. However, if the measured gas concentration goes above 50% of range during the second 8 minute inhibit period, the output lock is released and any receivers connected to the transmitter will indicate high gas levels.

ANALOG OUTPUT SIMULATION

The A12-17 transmitter provides the ability to simulate 4 different current output values in order to test the complete detection system. The output may be set to values of 4.0, 12.0, and 20.0, and may also be set to the "Trouble" value of 3.0 mA.

From the NORMAL display, activate the MODE control twice and the display will read "tEST". Activate the ENTER control. The display will change to "SEnS" and the TEST flag will be displayed near the top of the display. Activate the MODE control once and the display will change to tEST and the mA flag will be on. Activate the ENTER control once and the display will indicate 4 mA. The current output from the transmitter will now be locked on 4 mA. Use the UP or DOWN control to change the output to 12 mA, 20 mA, or "trbl" as desired. When "trbl" is displayed, the output will go to 3 mA, which is the output value used to indicate "Trouble" with the transmitter. The output current from the transmitter will change to the value shown on the display.

CAUTION: Simulation of 12 or 20 mA, or trb1 (3mA) outputs may cause receiving devices to activate alarms and/or control devices. Never simulate these outputs without inhibiting alarm receivers or notifying operating personnel that a system test is in progress.

To escape the output simulation mode, activate the ENTER control once.

CALIBRATION

A12-17 transmitters should be calibrated every 1-2 months. The frequency of calibration is dependent on the operating environment and the degree to which accuracy is important. Sensors exposed to dirt, oil mist, or vapors need more frequent calibration.

Transmitter calibration requires adjustment of both sensor zero and span. Sensor zero is adjusted when the sensor is exposed to zero air. Adjusting the span requires a source of span gas with a known concentration of combustible gas. Calibration kits, containing both zero air and span gas, are available from ATI in various sizes. Contact ATI or your local ATI representative if you have any questions on calibration gas sources.

NOTE: The output of the A12 transmitter is locked at 4 mA when in the calibration mode. This means that the 4-20 mA output will not change when span gas is applied. Only the LCD display will indicate changing gas concentrations. To verify output operation using span gas, apply gas while the transmitter is in the NORMAL mode of operation after calibration is complete.

ZERO ADJUSTMENT

As previously mentioned, adjusting the transmitter zero requires that the sensor be exposed to air that is free of combustible gas. If the area in which the sensor is operating is known to be gas free, then the transmitter can be zeroed without further equipment. If not, use of "zero air" from a gas cylinder is recommended. Zero air is available as part of all ATI calibration kits, or may be obtained from any specialty gas supplier. When zero air is to be used, a calibration adapter must be used. The calibration adapter provides a confined space around the sensor into which the zero air can flow. Calibration adapter provide tubing fittings at the bottom to connect air tubing as shown in Figure 15. If your sensor is furnished with the Auto-Test generator, a calibration gas fitting is supplied at the bottom of the sensor assembly and is left in place at all times. For these systems, no separate calibration adapter is needed.

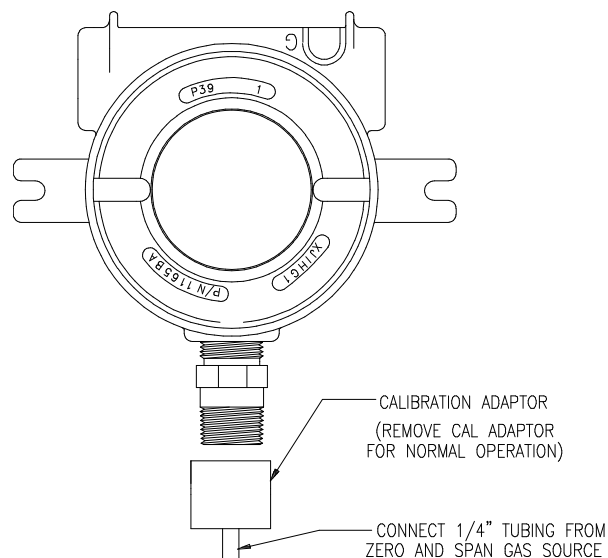

Figure 15 - Calibration Adapter Assembly

To zero the transmitter, allow zero air to flow to the sensor for 5 minutes. If the sensor is located in air known to be gas free, the 5 minute delay is not necessary. Set the new zero value as follows:

- Step 1 With the LCD indicating normal mode of operation, activate the MODE control repeatedly until the display shows "CAL". Activate the ENTER control. The display will change to "SEL" and the "Z" (for Zero) flag on the display will light.
- Step 2 Activate ENTER again and the display will indicate the gas concentration. The value should be close to zero. Observe the display to be sure it is not either increasing or decreasing.
- Step 3 When the display value is stable, activate ENTER again and any small sensor offset will be stored in memory. The display will briefly show "StOr", then change to "SEL" and the "S" (Span) flag will light. If you wish to span the transmitter, proceed to step 2 of the next section of this manual. If you only wish to set the zero, activate MODE until the display indicates "donE". Activate ENTER to return to the normal operating mode.

SPAN ADJUSTMENT

Adjusting span requires a source of reliable span gas. ATI calibration kits contain a 1% methane standard equivalent to 20% LEL. Other concentrations or other gas types may be used if preferred.

To adjust the sensing module span, proceed as follows:

- Step 1 Advance through the transmitter program using the MODE and ENTER controls until the display indicates "SEL" and the "S" and "% LEL" flags are lit. This display is indicating that you can now select the span mode.
- Step 2 Activate ENTER and the display will indicate gas concentration. The "S" flag will remain lit and the "mA  " flag will light indicating the transmitter output is locked at 4mA.
- Step 3 Screw a calibration adapter onto the sensor as shown in Figure 15. Connect your span gas source to either the inlet fitting on the calibration adapter or to the tube fitting supplied as part of the Auto-Test sensor assembly.
- Step 4 Turn on the calibration gas and allow it to flow for 3 minutes. The LCD should increase in response to the sensor being exposed to the target gas. After 3 minutes, use either the UP or DOWN controls to adjust the value on the display to 20% LEL (or appropriate value if another gas standard is in use).
- Step 5 Activate ENTER and the new span constant will be stored. The display will briefly show "StOr", then indicate "donE". Activate ENTER to return to normal operation.

mA OUTPUT ADJUSTMENT

Series A12 transmitters provide a method of adjusting (or offsetting) the 4 and 20 mA output values slightly in order to insure that other devices in the output loop read the correct value. In effect, these adjustments are the equivalent of fine zero and fine span controls.

Adjustment of the 4 and 20 mA values is done through the CAL mode. From the NORMAL display, activate MODE until the display reads "CAL". Activate ENTER once and then MODE twice so that the display reads "SEL" with the Z and mA indicators on. Activate ENTER and the display will change to "SET", with the Z and mA indicators still on. Use the UP or DOWN controls to move the 4 mA value up or down as required. The display will not indicate the output value. This must be read using a mA meter or by observing another display tied to the transmitter output.

When adjustment is complete, activate the ENTER control and the display will change to "SEL" with the S and mA indicators on. Activate ENTER and repeat the above process to adjust the 20 mA value as required. When adjustment is finished, activate ENTER to store the value and ENTER again when the display indicates "donE". This will take you back to the NORMAL display and mode of operation.

AUTO-TEST ENABLE/DISABLE SELECTION (Units with Auto-Test)

The automatic daily Auto-Test function on the A12-17 transmitter can be activated (enabled) or deactivated (disabled) from the calibration menu. Normally, this function will be enabled at all times so that the sensor response is verified regularly. However, should a problem arise with the generator, the Auto-Test function can be disabled while a new module or generator is obtained. If the sensor is still functional, disabling the Auto-Test allows the transmitter to continue normal operation without attempting its normal 24 hour test sequence.

If the transmitter was shipped with a sensor containing an Auto-Test generator, the Auto-Test function will be enabled at the factory. To disable this function, start from the NORMAL display and activate the MODE control three times to display "CAL". Activate ENTER once and then the MODE control 4 times. The display should now indicate "EnAb". Use the UP or DOWN control to toggle to "dISA". Activate the ENTER control to store the disable value. When the display indicates "donE", use ENTER to return to the NORMAL display.

CALIBRATION FOR OTHER COMBUSTIBLE GASES

As previously mentioned, a combustible gas sensor has a slightly different response to each combustible gas or vapor. In addition, the LEL (Lower Explosive Limit) represents different percent concentrations for different gases. For instance, the LEL for methane is 5% by volume while the LEL for butane is 1.9% by volume. Because of these factors, a combustible transmitter must be adjusted differently if the system is intended to detect a gas or vapor other than methane.

A 1% methane gas standard may still be used for calibration of combustible transmitters when used for other gases. However, the %LEL value set on the LCD will be different for each gas. Table 1 provides the LEL setting for various gases. The setting assumes the use of 1% methane as the span gas. As an example, to calibrate the transmitter for hexane detection using 1% methane standards, apply the 1% Methane gas in accordance with the span adjustment instructions but set the LCD to 50% in step 4.

TABLE 1

<u>GAS</u>	<u>% LEL</u>
Methane	20
Propane	35
n-Butane	35
n-Pentane	40
n-Hexane	50
Hydrogen	30
Methanol	30
Ethanol	40
Isopropyl Alcohol	55
Acetone	50
Methyl Ethyl Ketone	50
Benzene	55
Toluene	60
Di-ethyl Ether	10
Ammonia	15
Methyl T-Butyl Ether	46

SENSOR RESPONSE TEST

While zero and span adjustments are required only periodically, gas sensors should be checked regularly for proper response. The response check can be done quickly by simply aiming the outlet tube from the span gas cylinder at the face of the sensor and turning on the gas flow for 10-20 seconds. The sensor should begin to respond within 5 seconds. If the sensor does not respond, it should be replaced. This type of manual testing is normally not required for systems supplied with the Auto-Test generator. However, it should be used to test the sensor in the event of an Auto-Test failure.

CAUTION: This response test will cause the output to increase and may cause receiving devices to activate alarms and/or control devices. Never run a sensor response test without inhibiting alarm receivers or notifying operating personnel that a system test is in progress.

ERROR MESSAGES

The A12-17 constantly evaluates the condition of the sensor and the output loop to detect errors that might compromise the performance of the instrument. The following messages will appear on the LCD display if the transmitter detects certain failures.

- AUTO TEST FAIL :** This message is displayed if the transmitter is equipped with the Auto-Test option and the sensor fails to respond to 3 successive tests at one hour increments. Unusual environmental conditions can cause an occasional test failure, so the system will retest the sensor an hour later if a failure occurs. After 3 failures, the AUTO TEST FAIL message appears and the output goes to 3 mA. If this occurs, test the sensor with calibration gas to determine if the failure is due to the sensor or the gas generator. Sensor or generator replacement will most likely be needed. Should the Auto-Test failure message appear due to a generator failure, the transmitter will still perform its function. Activating the ENTER key will clear the alarm. Should the sensor detect a combustible level above 50% LEL, the failure condition will be over-ridden and the output will immediately reflect the measured gas value.
- SEnS FAIL :** This message is displayed when the transmitter has detected an open or short in either the active or passive sensor elements. When this error occurs, the output loop goes to 3 mA and will stay at that value until the problem is corrected. Activating the ENTER key will clear the alarm, **if and only if the problem has been corrected**. Otherwise the display will still display sens fail. Should the detector measure a gas value greater than 50% LEL, the unit will override the error condition and begin to transmit the measured gas value.
- LOOP FAIL :** This message is displayed in alternation with the normal LEL display if the transmitter detects an open circuit or short in the 4-20 mA output loop. The transmitter will continue to function normally and will accurately display combustible gas levels. However, any instrument tied to the output will not respond to changes at the transmitter. This condition should be corrected immediately as no alarms are likely to be activated during loop failure.
- U.r. FAIL :** This message is displayed when the transmitter has detected a negative zero drift greater than 15% of full scale. The transmitter output is locked at 3 mA. The display will alternate between the current gas concentration and "U.r.". The unit should be checked for proper operation. Sensor zero should be set and system response should be checked. Activating the ENTER key will clear the alarm.
- O.r. FAIL :** This message is displayed when the transmitter has detected a gas concentration greater than 110% full scale. The transmitter output will track the gas concentration and does not lock at any value. The display will alternate between "O.r." and the current gas concentration. Once the gas concentration falls below 110% full scale, the alarm can be cleared by activating the ENTER key.

SENSOR REPLACEMENT

Combustible gas sensors used in the A12-17 are warranted for 12 months and generally last 2 years or more in the absence of poisoning agents. When sensor replacement is required, it can be done easily and quickly. Power down transmitter in accordance with all applicable safety standards and procedures. Open the transmitter enclosure and unplug the transmitter electronics module. Disconnect the 3 or 5 sensor wires from the octal base and unscrew the sensor from the explosion-proof transmitter housing. Screw in the replacement sensor and reconnect at the octal base. After a new sensor has been connected, allow 4 hours for the new sensor to completely stabilize. Then perform a zero and span calibration as described on pages 21 through 22.

Sensor assemblies equipped with Auto-Test gas generators can have new generators installed at the factory. If the generator should fail and the sensor still show good response, contact ATI and arrange for generator replacement. The sensor in this type of assembly cannot be replaced separately.

SPARE PARTS LIST

<u>Part Number</u>	<u>Description</u>
03-0120	A12-17 Combustible Transmitter Module
03-0121	Explosion-proof Enclosure with Base
00-0252	C10-17 Combustible Gas Sensor
00-0258	Calibration Adapter (<i>sensor without auto-test</i>)
00-0261	Remote Calibration Adapter/Rain Shield (<i>sensor without auto-test</i>)
00-0298	Flowcell (<i>sensor without auto-test</i>)
00-0786	C28-17 Combustible Gas Sensor with Auto-Test
00-0789	Splash Guard (<i>for sensor with auto-test</i>)
00-0263	C10-17 Junction Box w/ Sensor
00-0787	C28-17 Junction Box w/ Sensor (<i>Auto-Test Version</i>)
03-0182	C28-17 Junction Box Assembly (No Sensor)
03-0183	C10-17 Junction Box Assembly (No Sensor)